

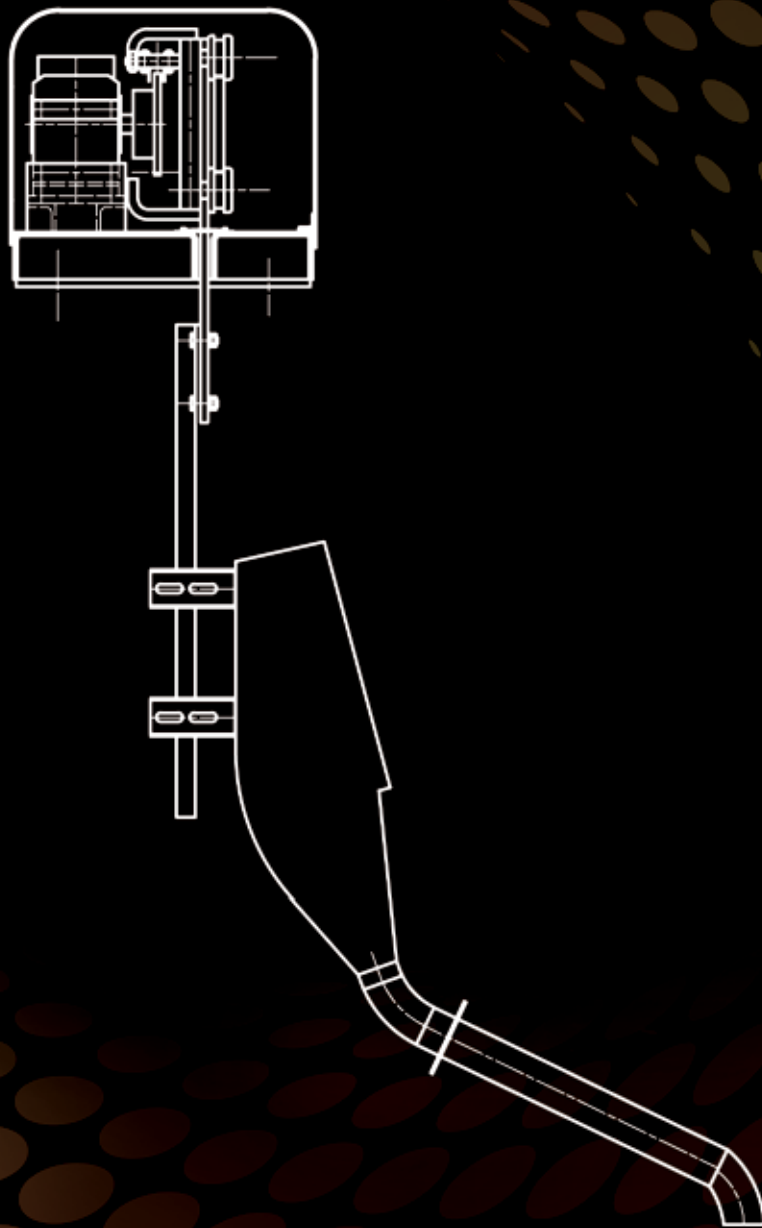

mip | PROCESS CORPORATION

# slurry samplers



## OUR COMPANY

MIP Process Corporation is a global Process Equipment sales and manufacturing company servicing the Mineral processing, Food & Beverage, Waste water, Chemical, Petrochemical and industrial markets. We pride ourselves on being truly customer-centric with unsurpassed levels of customer service.

MIP Process Corporation's mission is to be the preferred supplier of process equipment with an offering that is underpinned by:

- customer focus
- reliability
- innovation
- continuous improvement

We specialise in the supply of Process Equipment, but have the capability to assist with plant design around the Company's core technologies.

## BACKGROUND TO SLURRY SAMPLERS

The demands on modern day mineral processing plants are enormous, which means control and monitoring is of paramount importance. Sampling is a valuable tool to assist with optimisation and maximising of recoveries and grade. The accuracy of the sample is directly related to the design of the sampler. Since sampling is based on statistics, the minimising of statistical errors maximises the accuracy.

MIP Slurry Samplers can be supplied for a variety of applications in the mineral processing industry. Some applications where sampling has proved invaluable include:

- Cyclone Overflow (flotation feed)
- Final Tailings
- Intermediate Base Metal Concentrates
- Final Flotation Concentrate
- Carbon-in-Leach Streams

## SLURRY SAMPLERS TYPES AND SIZES

### Cross Cut Samplers

The MIP Automatic Cross-Cut Sampler is designed to operate as a primary sampler. Based on the launder size requirements and cutter parking of 8" on each side, various standard sizes are available to suit each application. The units are available with a width from 12" to 140". Pulp flowrates up to 1320 USG/h (5900m<sup>3</sup>/h) can be accommodated. The units are of rugged design with minimum maintenance and low operating costs. Secondary sampling reduces the final sample.

### Rotary Samplers

The rotary samplers can be used as primary units catering for pipes from 4" to 32". These samplers consists of a cylindrical enclosed steel housing with feed, discharge and sample ports. The housing is rubber lined for abrasion resistance, with the outer surface painted.

An 18" diameter rotary "vezin" sampler is used as the secondary unit to reduce the primary sample to a manageable size, e.g. 170 ounces per 8 hour shift. They are available with one (1) to four (4) cutters for optimisation of final slurry sample volume.

### Pipe Samplers

This is an in-line sampler with no moving parts for installation in pipes from 2" to 20". A continuous representative sample is provided due to the use of our propriety static mixing vanes prior to sampling.

### Control Panels

Single or dual fuction control panels can be provided.

A retrofit service is offered to enhance performance of existing slurry samplers.

Creating value  
through innovative  
superior designs and  
building of strong  
supply capabilities



## •• SLURRY SAMPLER DESIGN

MIP Slurry Samplers are designed to operate continuously for 24 hours per day. Process selections are based on our vast experience in the field of slurry sampling. It is our belief that process equipment should not be designed on the limit since metallurgical operations are dynamic.

## •• ENGINEERING STANDARDS

All engineering, design and construction is based on sound internationally approved engineering principles as well as practical applications.

## •• AFTER-SALES SERVICE

MIP Process Corporation products have been designed to ensure minimal maintenance with easily replaceable parts for minimum downtime.

All our products carry an eighteen (18) month warranty against the industry standard of twelve (12) months. This decreases the risk when buying MIP Process equipment. We offer an after-sales service and our Technical and Service departmental staff is available on a continuous seven (7) days a week basis to offer assistance.

A team of process and mechanical engineers, who have experience in Coal, Base Metals, Platinum and Gold markets, are available. Field service technicians provide further support.

## •• BENEFITS

A range of benefits are available to business partners when purchasing Slurry Samplers from us.

Feature	Benefits
Consistent travel velocity through stream	The cutter box is positively driven through the stream via a heavy duty chain, in the case of the cross-cut sampler, and a direct coupling to a gearbox on a rotary sampler.
Correct cutter speed	All our samplers are designed to travel at less than the maximum sampler cutter velocity, in order to ensure that we do not displace any portion of the stream that should have reported to the cutter.
Cutter box design	Replaceable blades ensure a consistent sample is taken every time.
Machined based	The base frame on the cross-cut sampler, is machined to ensure that the run-way bar and the cutter carriage are perfectly aligned.
Fiberglass cover	The cross-cut samplers have an easily removable cover. This allows for easy inspection of the internal components.
Automatic chain tensioner	A self-tensioning device is fitted to the units, negating the use of any additional supports and sprockets. The device always keeps the correct tension and prolongs chain life.

We require the following information to provide an optimum sampling system:

- Feed Pulp flowrate
- Description of stream, launder or pipe diameter
- Application
- Material characteristics
- Final sampling required e.g. 170 ounces per 8 hour shift

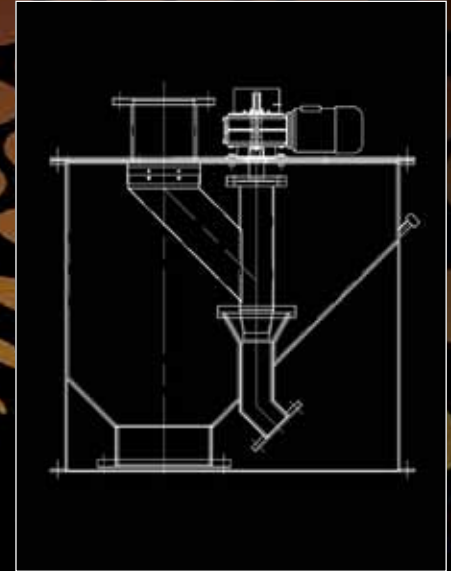

**Primary Rotary Sampler**

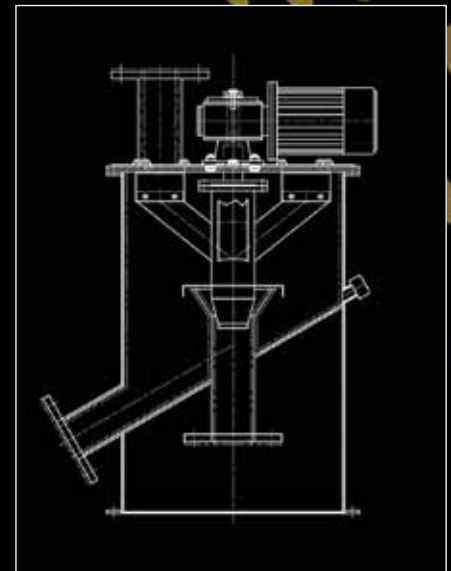

**18" Vezin Sampler**

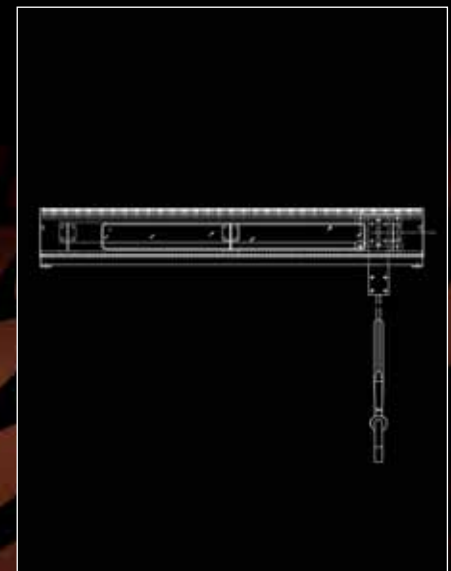

**Launder Sampler**



100ft $\Phi$  Thickener



85ft $\Phi$  Thickener in operation



MIP-200 Flocculant Plant



325ft<sup>2</sup> Linear Screen

### **Project Management**

Owing to the high level of importance that MIP Process Corporation places on delivery, we ensure that each project has a world-class management team. This is coupled with the resources of highly experienced subcontractors, for the different aspects of each project.

### **Low Investment**

Capital costs - Our equipment design is conservative and robust to ensure it is still in operation many years from now. We understand that process conditions can change and make allowances for this.

### **Test Facility**

A comprehensive test facility is available to our customers. Preliminary sizing can be done using our extensive database.

### **MIP Value Proposition**

The MIP designs consider not only the customer's process data, but also the long-term mechanical performance, maximum circuit efficiency, availability and minimised operating costs.

## **•• PRODUCT & SERVICES**

MIP PROCESS CORPORATION strives to design and manufacture process equipment that is technically advanced, reliable and customised for each application. We believe that each ore body is different and a 'fit for all design', is not necessarily the optimum solution.

Our designs are simple yet robust and reliable. Our philosophy is to minimise the customer's total operating costs, thus minimising capital and operating expenditure.

The full product range includes:

- Attrition Scrubbers
- Clarifiers and Thickeners
- Flocculant and Reagent Make-up Plants
- Horizontal Linear Screens
- Slurry Samplers

## **•• CONTACT DETAILS**

Address: 770 'L' Street, Suite 950, Sacramento, CA, 95814

Telephone: +1-916-449-3994

Fax: +1-916-449-3984

eFax: +1-916-449-3963

Email: [sales-usa@mipprocess.com](mailto:sales-usa@mipprocess.com)

Website: [www.mipprocesscorp.com](http://www.mipprocesscorp.com)